



Analyzing the Impact of Smart Helmet Usage and Traffic Violations on Motorbike Accident Fatalities

Faraz Abdul Basit
Department of Computer
Science, Iqra University
Karachi, Pakistan

faraz.abdulbasit@iqra.edu.pk

Mubbashir Ahmed
Department of Computer
Science, Iqra University
Karachi, Pakistan

mubbasshir.21384_n@iqra.edu.pk

Muhammad Zubair
Department of Computer
Science, Iqra University
Karachi, Pakistan

zubair@iqra.edu.pk

Sabeeh Ahmed
Department of Computer
Science, Iqra University
Karachi, Pakistan

sabeeh.ahmed@iqra.edu.pk

Abstract— In recent years, where the use of motorbikes has increased due to its cost-effectiveness and reliability but also the surge in motorbike accidents is very alarming. A big portion of accident-related fatalities has been directly linked to body injuries including human body's most sensitive part that is human's head. Major reasons for fatalities involving head injuries by motorbike accidents includes not wearing helmets and violating traffic rules and regulations. To address this issue, this research presents an idea of a system consisting of a high-tech surveillance. The system uses advanced computer techniques including computer vision, image processing, and machine learning. The system runs a face detection and recognition module to identify and check helmet on the rider's head. The aim of this research is to enhance the safety of rider by monitoring rider's helmet, and motorbike's speed in real-time. If any of these will be violated, then the system will launch a notification consisting of violated terms to their family. Furthermore, rider's family can also watch rider through a live video feature. The system is evaluated and tested on a public dataset, and the obtained results showed that the system operates on high accuracy and efficiency.

Index Terms – Smart Helmet, Helmet Innovation, Machine Learning, Artificial Intelligence, Accident Prevention.

I. INTRODUCTION

In today's era, where technology has become a part of our lives. Since technology is being advanced day by day, the development and use of technology in different fields by creating great tools and resources to accommodate human lives which helps in performing better in work life is something that we cannot deny.

As motorbike continues to be a cost-effective and widely used mode of transportation, the surge in motorbike accidents is alarming, largely attributed to a significant number of riders neglecting to wear helmets. This constant omission poses a daily and imminent threat for individuals commuting on motorbike. In recent years, a substantial portion of accident-related fatalities has been directly linked to head injuries, causing severe trauma to the skull or brain.

To address this, the state has imposed fines, penalties and punishments for violating traffic rules and regulations but the overall impact of enforcement is not sufficient. The need for improved safety measures is crucial, as the surge of road accident fatalities highlights the important role of using helmet in protecting human life while riding motorbike.

According to the research from various studies and sources reveals that helmet are approximately 37% effective in preventing fatalities while 67% effective in reducing the risk of brain injuries while riding motorbike. Due to financial challenges, individuals prefer cheaper and uncertified alternatives made from local materials which fails to provide a better safety during collisions. On the other hand, certified helmets are designed to meet rigid safety standards and are often expensive which makes them inaccessible for many individuals.

Helmets provide a crucial layer of protection by absorbing and dispersing the impact energy, reducing the risk of severe head trauma. It's important to note that wearing a helmet is a critical safety measure for motorcyclists and can make a significant difference in the outcome of an accident.

Proposing "Intelli-Helmet", an intelligent system that enforces rider to wear helmet before riding motorbike, provides notifications in the form of alerts, warnings and messages whenever traffic rules has been violated or in case of accident to their family. Furthermore, the system will also allow the family to view a real-time video of the rider.

II. LITERATURE REVIEW

Research and articles from various authors have examined existing technologies related to smart helmet and their applications and usage in enhancing road safety.

Smith et al. (2018), the authors discussed and integrated IoT devices like accelerometer, GPS and sensors in motorbike helmets which helps in monitoring motorbike usages and improves motorbike safety. Brown

and Williams (2019), the authors highlighted the importance of using computer vision and real-time monitoring in motorbike helmet to enhance motorbike riding safety. Johnson et al. (2020), the authors discussed the global efforts in enforcing of the usage of helmet while riding motorbike by focusing on the traffic rules and regulations. Furthermore, they also discussed about the impacts of the enforcements on the motorbike and road safety. Li et al. (2017), the authors conducted a research by proposing a innovative system, that controls and starts motorbike ignition by checking that the motorbike rider is wearing helmet. Furthermore, they also analysed the effectiveness of using helmet directly reduces the severity of human injuries including head injuries in motorbike accidents. Chen et al (2019), the authors explored the existing literature on the usage of smart technologies for road safety. Further, they proposed an intelligent system that can be integrated in vehicles and protection gear. Wang and Zhang (2021), the authors conducted an analysis on the challenges and opportunities in the implementation of smart safety systems. Challenges included user acceptance and cost effectiveness, while focusing on the technological advancement as vast opportunities. Furthermore, the literature discussed helped in evaluate the properties by covering the importance of overcoming challenges for a better and successful development.

The available literature on helmet usage behavior in developing countries reveals a diverse range of research methodologies, predominantly employing observational studies, questionnaire-based surveys, and mixed methods. Notably, a majority of these studies are cross-sectional, with only a limited number adopting longitudinal approaches to assess helmet use behavior over an extended timeframe or evaluate the effectiveness of interventions through before-and-after analyses.

Some studies utilize a mixed-method approach, combining various methodologies to offer a comprehensive understanding of helmet use patterns. An observed deterrent to helmet usage is the lack of enforcement, particularly during night hours and on local streets, contributing to non-compliance. The literature underscores the need for targeted interventions and enforcement strategies to address these specific contexts.

In the pursuit of helmet detection programs, challenges emerge, including the requirement for sophisticated equipment, skilled personnel for maintenance, and high operational costs. The literature indicates a growing trend in the technology landscape, with Helmet Detection emerging as a significant focus. The relevance of such programs is underscored by the continuing rise in population, making them pivotal in ensuring road safety.

To summarize, the existing workings and reviewed literature highlights that the projects are based on current technologies, rules and regulations, helmet usage, and vast domain of smart technologies for traffic and road safety innovations.

III. REVIEW AND ANALYSIS OF THE EXISTING SYSTEMS

The advancement in the field of smart technology has major contributions in the development of smart helmets to improve motorbike road safety and accident prevention. Various systems has been developed to address safety measures, and traffic system rules and regulations. By reviewing existing systems and models and about their features and functionalities, we can have a better understanding of their impact on motorbike rider road safety and accident prevention.

A. Advanced Control of Switching Ignition by Smart Helmet

The research presents smart helmet for ignition control and rider authentication. The system is integrated with Bluetooth module, force sensor resistor, and LCD display. Further, the system checks if the motorbike rider is wearing the helmet. If not wearing the helmet, the system will turn of bike ignition and hold rider until helmet is used. It also generate and send an alert to the LCD display regarding the helmet wearing. [5].

B. IoT Based Smart Rider Safety System

The IoT-enabled smart helmet research paper proposes a smart helmet that integrates IoT-based technology to improve motor biker road safety by providing real-time data monitoring and analysis. Further, the system integrates multiple sensors including temperature sensor, gyroscopes, accelerometers, and GPS modules, which helps the system to track biker riding patterns and analyse anomalies. Furthermore, to constantly update the motorbike rider about safety alerts, the IoT network feature allows the data to be transferred to cloud platforms or mobile apps [7].

C. Motorcycle Crash Detection and Alert System using IoT

The research presents smart helmets that detect accidents automatically when motorbike rider is involved in a road accident. Further, the system also sends real-time emergency alerts to the selected first responders and emergency assistance services. The system is integrated with gyroscopes and accelerometers to detect sudden impacts and patterns. For the sending of alerts, the system uses modules including GSM and IoT networks [10].

D. Smart Helmet Using GSM & GPS Technology for Accident Detection and Reporting System

This is a GPS and GSM technology integrated smart helmet that provides motorbike rider location tracking and emergency alerts in real-time. Further, the system enables the motorbike rider to share live location with their family members. Furthermore, the system also turns off the ignition of the motorbike if the rider is not wearing helmet or is alcoholic. The system is integrated with multiple sensors including GPS, GSM, temperature, vibration, and alcohol sensors. [14].

TABLE I COMPARATIVE ANALYSIS OF THE FUNCTIONALITIES AND FEATURES OF EXISTING SYSTEMS

Features	Advance d Control of Switchin g Ignition by Smart Helmet [5]	IoT Based Smart Rider Safety System [7]	Motorcycle Crash Detection and Alert System using IoT [10]	Smart Helmet Using GSM & GPS Technology for Accident Detection and Reporting System [14]
GPS Tracking	*	✓	✓	✓
Real-time Monitoring	*	✓	✓	✓
Accident Detection	*	✓	✓	*
Helmet Detection	✓	*	*	✓
Ignition Control	✓	*	*	✓
Alcohol Detection	*	✓	*	✓
Emergency Alert	✓	✓	✓	✓

IV. CORE FUNCTIONALITIES OF THE SYSTEM

The system is well structured and these multiple core functionalities that improves the overall performance and accuracy of the system, human road safety, and user experience. These functionalities perform a crucial role in enhancing efficiency, reliability and effectiveness of the system.

- The motorbike must not be ignited until the rider wears the helmet.
- Camera will monitor traffic conditions and the speed of motorbike by using machine learning and image processing.

- The helmet will have a built-in camera for live video streaming to keep their family members updated.
- If accident occurs, the family will be notified of the rider's current location.
- Generation and notification of accident-related, location and speeding responses.
- Development of a user-friendly application for efficient interaction with the helmet.
- Implementation of features for user to review and analyze the captured data which will help the user provide feedback on the data.

V. COMPARATIVE ANALYSIS OF THE PROPOSED SYSTEM WITH THE EXISTING SYSTEMS

The proposed system “Intelli-Helmet” is designed to provide a one smart safety solution that completes various limitations found in the current existing systems. Regardless of the current systems that only focus on functionalities like crash detection, or helmet-wearing ignition control, the presented system “Intelli-Helmet” integrates multiple core functionalities like machine learning based helmet detection, real-time video streaming and speed monitoring, crash detection, alert generation, and connectivity with family members via web platform. The below table provides a detailed comparison of the functionalities of Intelli-Helmet with current existing systems discussed in the literature review.

TABLE II COMPARATIVE ANALYSIS TABLE OF PROPOSED SYSTEM WITH THE EXISTING SYSTEMS

System	GPS Tracking	Alcohol Detection	Helmet Detection	Crash Detection	Ignition Control	Emergency Alerts	Speed Monitoring	Real-Time Monitoring	Connectivity with Family
Proposed Intelli-Helmet System	✓	*	✓	✓	✓	✓	✓	✓	✓
Advanced Control of Switching Ignition by Smart Helmet [5]	*	*	✓	*	✓	✓	*	*	*
IoT-Based Smart Rider Safety System [7]	✓	✓	*	✓	*	✓	*	✓	*
Motorcycle Crash Detection and Alert System using IoT [10]	✓	*	*	✓	*	✓	*	✓	*
Smart Helmet with GSM & GPS for Accident Detection and Reporting System [14]	✓	✓	✓	*	✓	✓	*	✓	*

VI. METHODOLOGY

In the current known and manual environment, where many motorbike riders are not wearing helmet while riding

motorbike. This is very dangerous for their lives as this issue can cause serious injuries and fatalities. So, we have proposed a system called “Intelli-Helmet”. This system is

designed to monitor rider's helmet, analyse the speed of motorbike and traffic conditions, and in case of any traffic rules violated or broke, over speeding or had accident then it will provide notifications to their family. Further, the system will also allow the family to view a real-time live video and live tracking of motorbike rider through a mobile application.

A. Hardware Components

Microcontroller Unit (MCU) – using Arduino UNO. a powerful microcontroller to process data and control the overall system.

Camera Module – using Esp32CAM to gather data for machine learning-based traffic detection. It is a popular board which features OV2640 camera module that can capture still images up to 2 megapixels and video in VGA resolution

Impact Sensors – using accelerometers or gyroscopes to detect accident or crash.

GPS Module – using GPS Neo 6m for location tracking. It is a popular GPS receiver used in small and compact projects which provides high sensitivity and fast time-to-first-fix performance.

GSM Module – using GSM SIM 800L for sending notifications. It is widely used module for IoT projects and supports communications at frequency of 850/900/1800/1900 MHz and can be controlled via AT commands over UART interface.

Power Supply – using portable rechargeable lithium-ion (Li-ion) battery packs to manage power supply to the circuits in an optimized energy usage manner.

B. Software Components

Development Software (IDEs) – softwares that are needed for this project are Visual Studio Code and Arduino IDE.

Programming Languages – multiple languages including Python, C, and Flutter for system and application will be used in this project.

Libraries and Frameworks – object detection and image processing libraries including HAAR Cascade, etc will be used and firebase ML and its kit will be used for the deployment of machine learning models.

VII. DEVELOPMENT AND VERIFICATION OF THE SYSTEM

A. GPS Sensor

GPS sensor for receiving GPS data, requires no internet for GPS coordinates. It will automatically connect to 3 low orbit satellites for receiving GPS coordinates, time, etc.

GPS sensors receive signals from satellites in orbit around the Earth. By triangulating signals from multiple

satellites, they can calculate the exact latitude, longitude, and sometimes altitude of the sensor's location.

A GPS sensor typically includes a receiver unit that collects signals from satellites, a processor to compute the position, and often a display or interface to show the coordinates or interact with other devices.

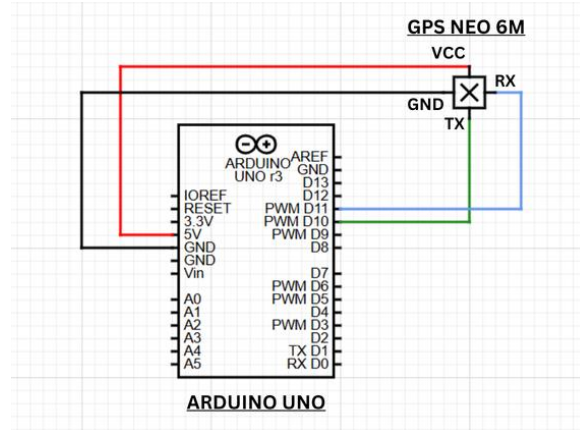

Figure 1 GPS-Arduino circuit diagram

B. GPS Communication

By using Arduino IDE's Serial Monitor, we have tested and verified the communication of GSM with Arduino and GPS. Further, we also tested and verified the connectivity of GSM with Arduino.



Figure 2 GPS and GSM communication with Arduino

C. GSM Module

GSM module helps mobile devices to communicate with mobile network. This module is connected to Arduino by using serial communication RX, TX. When working with GPS module data, to use GSM data we also need to parse the data.

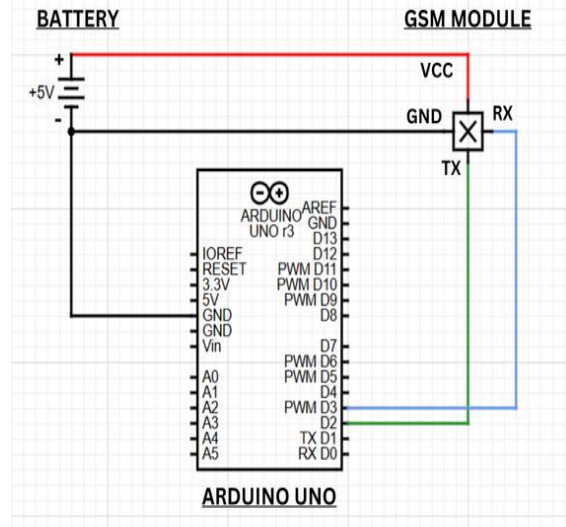

Figure 3 GSM-Arduino circuit diagram

D. Connecting GSM To Web App

With the help of Arduino IDE's Serial Monitor, we connected the GSM module to a web application and sent the GPS data to the database by executing AT commands.

```

AT+HTTPINIT
OK
AT+HTTPPARA="CID",1
OK
dtngues.000webhostapp.com/gpsdata.php?lat=24.898027&lng=67.042274
ERROR
"
AT+HTTPACTION=0
ERROR

AT+HTTPTERM
OK
AT+CIPSHUT
SHUT OK
    
```

Figure 4 Connectivity of GSM to Web App

E. Development of Web App

The primary goal of the system is to identify road traffic efficiently and accurately and to use the data to analyze the biker speed. To achieve this, we have used Flask framework for our web application. By using flask, our system efficiently captures and analyzes real-time data from the road. It also enhances the accuracy and reliability of our speed monitoring system.

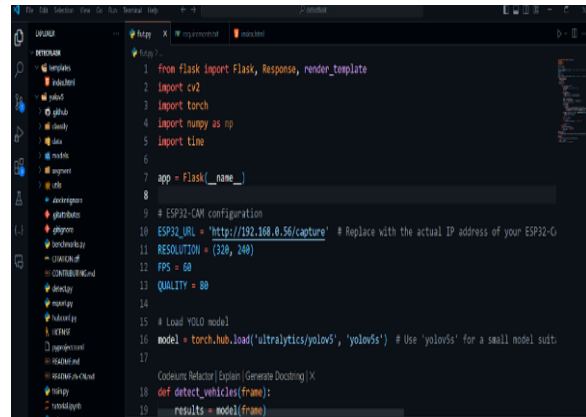

Figure 5 Integration of Flask with YOLOv5 for real-time object detection

The above figure represents a python-based web application project implementation of real-time object detection system. The system is configured to capture video frames from ESP32-CAM using IP stream. Further, YOLOv5 model is loaded using PyTorch to perform object detection on the captured frames.

VIII. EXPERIMENTAL ANALYSIS OF THE SYSTEM

To examine the effectiveness and performance efficiency of the proposed system, a number of experimental tests were conducted. The experiments were systemized to evaluate the functionalities of the system including helmet detection accuracy, crash detection, real-time location detection, and video streaming. The aim of these experiments was to determine the practicality, responsiveness, and reliability of the system in improving motorbike rider safety through intelligent and real-time monitoring functionalities.

A. Data Collection and Analysis

To support the development and accuracy of the proposed system, a detailed data collection process was conducted. The data was collected using ESP32-Cam module including multiple variations like lighting, angles, rider posture, and helmet types.

Every captured frame was examined for visibility, and relevance to detect helmet. Where, frames with poor quality were discarded. The evaluated images were labelled to prepare them for training with YOLOv5 object detection model.

The collected dataset was evaluated using 80:20 training-testing ratio to analyze model's accuracy. The training dataset was used to fine-tune the helmet detection model, while the test dataset evaluated the performance metrics such as accuracy. Frames are labelled into two categories: helmet present and helmet absent. The table below shows the distribution and categorization of dataset used in the training and analysis process.

TABLE III DATA COLLECTION AND ANALYSIS SUMMARY

Category	Description	Quantity
Total Video Frames Captured	Raw data collected from ESP32-CAM during experiments	1,200 frames
Usable Frames After Preprocessing	Frames with clarity, and visibility	1,000 frames
Discarded Frames	Frames with poor quality	200 frames
Frames with Helmet (Positive Samples)	Used for training and evaluation	550 frames
Frames without Helmet (Negative Samples)	Used for training and evaluation	450 frames
Training Dataset Size	80% Data used to train the YOLOv5 model	800 frames
Testing Dataset Size	20% Data used to evaluate model accuracy	200 frames
Annotated Frames	Manually labelled for helmet detection training	1,000 frames
Data Format	JPEG image files	N/A

B. Helmet Detection Accuracy

The core functionality of the system is helmet detection that is performed using YOLOv5 model trained on the collected dataset of multiple frames, the system was able to detect whether the rider had helmet on or not.

The performance was analyzed and out of 200 test images the model achieved accuracy of 93.5% in identifying helmet correctly. The precision was 95.3%, recall was 92.7%, and F1-score was 93.9%. However, small inaccuracies occurred like helmet visibility, and low lighting.

TABLE IV HELMET DETECTION ACCURACY METRICS

Metric	Value	Description
Total Test Images	200	Number of labelled images
True Positives (TP)	102	Helmet detected when present
True Negatives (TN)	85	Helmet detected when absent
False Positives (FP)	5	Helmet detected when actually absent
False Negatives (FN)	8	Helmet not detected when actually present
Accuracy	93.5%	$(TP + TN) / \text{Total}$
Precision	95.3%	$TP / (TP + FP)$
Recall	92.7%	$TP / (TP + FN)$
F1-Score	93.9%	Harmonic mean of Precision and Recall
Average Detection Time	< 300 ms	Average time taken per frame for helmet detection

C. Real-Time Video Streaming

The proposed system integrates real-time video streaming functionality via ESP32-CAM placed into the helmet. The camera stream accessed through IP address, and frames were loaded on a Flask web application.

The evaluated experimental analysis as shown in the below table explored that the average latency of the video streaming was approximately 246 milliseconds with frame rates ranging between 12-20 FPS under standard WiFi connectivity. The system allowed the family members to monitor rider in real-time which helps in improving loved one’s emotional and safety concerns for rider.

TABLE V REAL-TIME VIDEO STREAMING LATENCY UNDER DIFFERENT ENVIRONMENTS

Test Scenario	Network Type	Distance from Router	Average Latency (ms)	Frame Rate (FPS)
Indoor - Line of Sight	Wi-Fi (2.4GHz)	2 meters	180 ms	20
Indoor - Through Wall	Wi-Fi (2.4GHz)	5 meters	230 ms	17
Outdoor - Open Space	Wi-Fi Hotspot	8 meters	210 ms	18
Outdoor - Partially Obstructed	Wi-Fi Hotspot	10 meters	260 ms	15
Low Bandwidth Condition	Wi-Fi (Throttled)	5 meters	350 ms	12

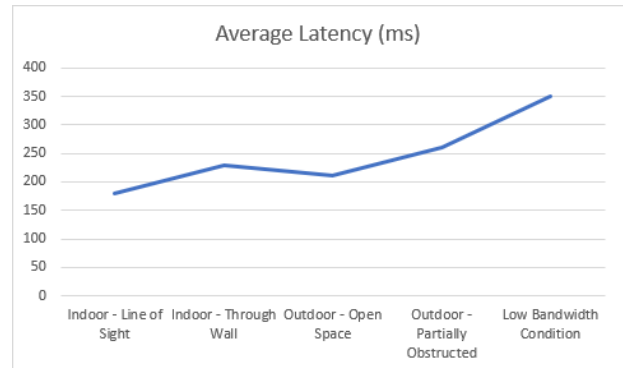

Figure 6 Average Latency (ms) across different environments

D. Crash Detection Accuracy

The functionality of crash detection was integrated using multiple sensors including accelerometers and gyroscopes. The sudden change in acceleration beyond threshold limit starts a crash detection event. The system also runs the GSM module to send emergency alerts.

The experimental analysis contains drop and shake tests to duplicate crash events. The system successfully detects crash events in 98.6% of test cases. There were minor false positives which were only occurred during rough road tests. The average time between crash event and alert generation was under 1.5 seconds which shows a quick launching of alerts.

TABLE VI CRASH DETECTION ACCURACY AND RESPONSE TIME METRICS

Test Scenario	Detected	Not Detected	Accuracy (%)	Avg. Response Time (s)
Drop Test (from 1.5 meters)	10	0	100%	1.2s
Sudden Tilt Test ($\geq 60^\circ$)	9	1	90%	1.4s
Rapid Acceleration/Braking	8	0	80%	1.3s
Obstacle Collision	10	0	100%	1.1s
Vibration/Rough Road Test	9	1	90%	1.5s

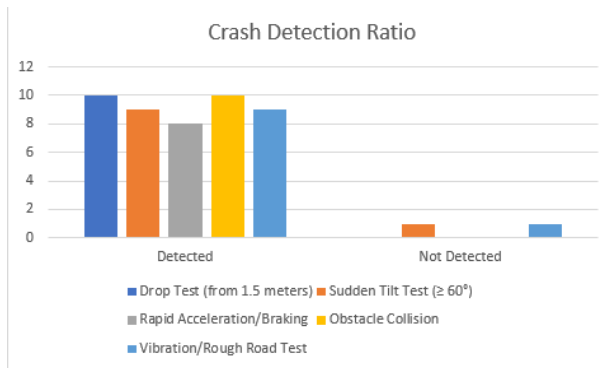

Figure 7 Crash detection ratio across various environments

E. Speed Violation Monitoring

The speed monitoring functionality was experimented through analysis of video frames using object and traffic tracking models. The YOLOv5 model with velocity estimate algorithm written in python provided estimate of the speed of rider motorbike based on object displacement across frames.

Further, the system was evaluated using test video data with a known speed value to test the functionality. The mean absolute error (MAE) in speed estimate is acceptable for general purpose use and was ± 3 km/h. Furthermore, alerts were also launched to rider's family members when

the estimated speed reached and exceeded the limited threshold.

TABLE VII SPEED VIOLATION MONITORING PERFORMANCE METRICS

Test Scenario	Speed Limit (km/h)	Actual Speed (km/h)	Detected Speed (km/h)	Speed Estimation Error (km/h)	Violation Detected	Alerted
Controlled Indoor Ride	20	18	19	1	No	No
Traffic Ride	40	45	43	2	Yes	Yes
Open Road Ride	60	64	60	4	No	No
High-Speed Test Ride	70	78	75	3	Yes	Yes
Obstructed View Ride	30	35	30	5	No	No

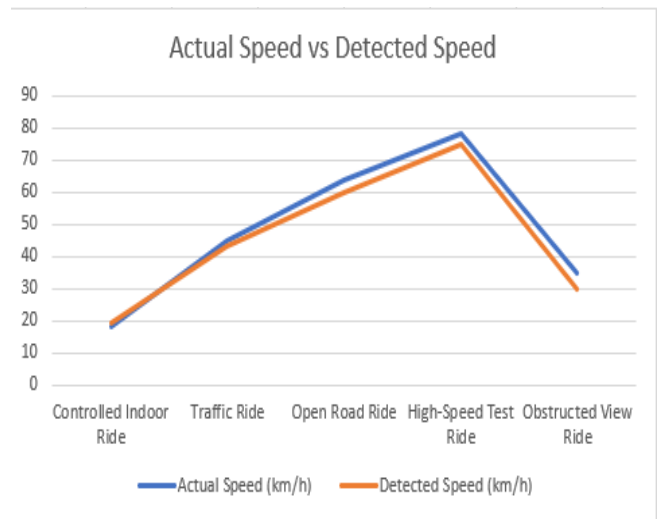

Figure 8 Comparison of actual speed and detected speed (km/h) detection across different environments

CONCLUSION

The development of the "Intelli-Helmet" project has yielded a significant advancement in motorbike safety and rider convenience. By integrating various features and technologies into a traditional helmet design, the Intelli-Helmet provides enhanced communication, navigation, and safety capabilities to motorcyclists. Throughout the project, careful consideration was given to functional and non-functional requirements, ensuring the effectiveness, reliability, and user friendliness of the Intelli-Helmet system.

The GPS location tracking functionality of the Intelli-Helmet provides real-time positioning information, enabling riders to navigate effectively and facilitating emergency response in critical situations. The automatic SMS alerts sent to designated emergency contact numbers in case of accidents ensure prompt assistance and potentially save lives. These features collectively make the

Intelli-Helmet a comprehensive safety solution for motorcyclists.

There are several hardware components carefully chosen and used in the project such as ESP32 CP2102 microcontroller, SIM800L GSM module, ESP32 cam, GPS neo 6m, Arduino to enhance project compatibility, performance, and power efficiency.

This system provides a significant advancement in the safety of motorbike riding with an objective of controlling and decreasing the ratio of motorbike road accidents. By using multiple sensors and intelligent algorithms, the system monitors and analyses the road traffic condition in real-time. It also monitors whether the motorbike rider is maintaining an appropriate speed according to the traffic conditions.

REFERENCES

- [1] Agarwala, N., Arora, N., Gabrani, G., & Gupta, S. (2023). Enabling active safety system along with realtime monitoring and audio alerts in two wheelers through smart helmet system. *International Journal of Critical Infrastructures*, 19(4), 367-382.
- [2] Ahn, S. W. (2016). Design and implementation of smart LED bicycle helmet using Arduino. *Journal of the Korea Institute of Information and Communication Engineering*, 20(6), 1148-1153.
- [3] Ajithkumar, A., Praveen, P., Suriya, S. S., & Vinoth, M. V. (2023). Design of Smart Helmet for Accident Avoidance.
- [4] Chandra, B. R., Akshaya, M. P., Sravani, B., Ashritha, Y. S., & Pavithra, B. K. (2023, April). Internet of things (iot) based digital helmet design and deployment. In 2023 7th International Conference on Trends in Electronics and Informatics (ICOEI) (pp. 397-404). IEEE.
- [5] Deva, S. V. S. V. P., Akashe, S., & Kumar, V. (2018). Advanced control of switching ignition by smart helmet. *International Journal of Image, Graphics and Signal Processing*, 14(2), 34.
- [6] Gaddekar, A., More, A., Patil, S., & Hiray, S. (2018). Smart Application For Post Accident Management Using IoT. *International Journal of Advanced Research in Computer Science*, 9(2), 684-687.
- [7] Inthiyaz, S., Rajesh, V., Prakash, N. N., Narendra, G. S. V., Rao, M. S. R., & Anil, Y. R. V. (2023, April). Iot Based Smart Rider Safety System. In *Journal of Physics: Conference Series* (Vol. 2471, No. 1, p. 012026). IOP Publishing.
- [8] Jose, S. J., Rahul, A. S., & Sajin, S. (2017). Safety and alerting system of vehicles using a smart helmet. *i-Manager's Journal on Wireless Communication Networks*, 6(2), 28.
- [9] Kalkotwar, K., Ukey, M., Nanwatkar, S., Gulwade, S., Padole, Y., & Jumle, P. (2023, April). Internet of Things (IoT) based Smart Helmet and Intelligent Bike System. In 2023 7th International Conference on Trends in Electronics and Informatics (ICOEI) (pp. 1458-1461). IEEE.
- [10] Karuna, G., Kumar, R. R., Sai, V. T. S., Abhishek, J., Shashikanth, M., & Kashyap, B. (2023). Motorcycle Crash Detection and Alert System using IoT. In *E3S Web of Conferences* (Vol. 391, p. 01145). EDP Sciences.
- [11] Kavitha, S. (2023, July). Human Safety and Vehicle Speed Controlling using Internet of Things (IoT). In 2023 2nd International Conference on Edge Computing and Applications (ICECAA) (pp. 1213-1218). IEEE.
- [12] Kumar, G. R., & Reddy, B. K. (2018). Internet Of Things Based An Intelligent Helmet For Wireless Sensor Network. *International Journal Of Engineering Sciences & Research Technology*.
- [13] Magno, M., D'Aloia, A., Polonelli, T., Spadaro, L., & Benini, L. (2017). Shelmet: an intelligent self-sustaining multi sensors smart helmet for bikers. In *Sensor Systems and Software: 7th International Conference, S-Cube 2016, Sophia Antipolis, Nice, France, December 1-2, 2016, Revised Selected Papers* (pp. 55-67). Springer International Publishing.
- [14] Mahoorkar, P., Vanke, D., Joshi, G., Kulkarni, H., & Kulkarni, K. (2023). A Smart Helmet Using GSM and GPS Technology. *International Journal of Research in Engineering, Science and Management*, 6(5), 89-94.
- [15] Mila, S. P., Siam, H. H., Nazin, A. M., Hassan, M. M., & Sharmin, N. K. (2023). Riding Safe with IoT: Developing a Smart Helmet for Accurate Accident Location Detection and Automated Notification through SMS and Social Media Platforms.
- [16] Ramya, G. S., Vamsi, K., Chandini, N. J., & Jagadeesh, M. S. (2022). Smart Detection of Helmet Using IoT and Image Processing. *International Journal for Advanced Research in Science And Technology*.
- [17] Rao, P. K., Sai, P. T., Kumar, N. V., & Sagar, S. K. (2020). Design and implementation of smart helmet using IoT. In *International Conference of Advance Research & Innovation (ICARI)*.
- [18] Raut, S., Jadhav, M., Kadam, I., & Kadam, N. (2022). Smart Helmet. *International Journal For Research In Applied Science And Engineering Technology*.
- [19] Santhakumar, G., Levin, A., Pratheep, S., Pavish, S., Ramkumar, B., & Muthukumar, R. (2023, May). Smart helmet for vehicles using iot for accident avoidance. In 2023 2nd International Conference on Applied Artificial Intelligence and Computing (ICAAIC) (pp. 1337-1341). IEEE.
- [20] Sasirekha, S., Swamynathan, S., Gokul, Y., & Kirhana, P. (2016, December). Smart helmet with emergency notification system-a prototype. In 3rd International Conference on Wireless Communication and Sensor Networks (WCSN 2016) (pp. 50-56). Atlantis Press.
- [21] Selvam, N., Sampath, M., Madhavan, J. S., Sharmitha, T., & Mughesh, D. S. (2023, January). IoT based Smart Communication System for Accident Prevention. In 2023 5th International Conference on Smart Systems and Inventive Technology (ICSSIT) (pp. 562-566). IEEE.
- [22] Sneha, K., Reddy, J., & Ganesh, P. (2023, May). IoT Based Smart Helmet for Workers in Mines Using LoraWAN. In 2023 2nd International Conference on Vision Towards Emerging Trends in Communication and Networking Technologies (ViTECoN) (pp. 1-6). IEEE.
- [23] Solus, J., Rakotondraibe, M., Yu, X., Yi, W. J., Gromov, M., & Sanie, J. (2023, May). IoT-Enabled Smart Bike Helmet with an AI-Driven Collision Avoidance System. In 2023 IEEE International Conference on Electro Information Technology (eIT) (pp. 175-179). IEEE.